

IWAKI Direct Drive Pump

RD Series

Instruction Manual

 Read this manual before use of product

Thank you for having selected the Iwaki Direct Drive Pump RD series. This manual deals with the correct handling and operation procedures and troubleshooting methods for the pump. To make maximum use of the pump and to ensure safe, long operation, please read this manual carefully prior to operating the pump. Pay special attention to the “Warning” and “Caution” sections as they relate to matters of safety and proper usage of the pump.



Contents

Chapter	Page
1. Safety Instruction	1, 2
2. Unpacking and Inspection	3
3. Operating Principle	3
4. Specification and Model Identification Code	4
5. Dimension	5
6. Performance Curve	6
7. Main Parts and Label	7
8. Name of Parts	8
9. Handling	9, 10
10. Installation, Piping, and Wiring	11 ~ 13
11. Operation	14 ~ 16
12. Troubleshooting and Maintenance	17, 18

Important Instruction

For the Safe and Correct Handling of the Pump

- Read the “Safety Instructions” sections carefully to prevent accidents involving your customers or other personnel and to avoid damage or loss of other assets. Always follow the instructions and advice found in these sections.
- Observe and abide by the instructions described in this manual. These instructions are very important for protecting pump users from dangerous conditions and situations related with the use of the pump system.
- The symbols relate to the following meanings described below:

 Warning	Nonobservance or misapplication of the contents of the “Warning” section could lead to a serious accident, including death or injury.
 Caution	Nonobservance or misapplication of the contents of the “Caution” section could lead to serious physical injury to the user or serious damage to the product.

Types of Symbols



Indicates that “Warning” or “Caution” must be exercised. Inside this triangle, a concrete and practical image provided as a warning or caution message is depicted.



Indicates a prohibited action or procedure. Inside or near this circle, a concrete and practical image of the activity to be avoided is depicted.



Indicates an important action or procedure which must be performed or carried out without fail. Failure to follow the instructions herein can lead to malfunction or damage to the pump.

1. Safety Instruction

Warning

- **Turn off the power supply.**

Working without disconnecting the power supply may cause an electrical shock. Before engaging upon any working procedures involving the pump, make sure to turn the power supply switch off and to stop the pump and other related devices.



- **Terminate operation.**

When you detect or become aware of a dangerous sign or abnormal condition during operation, terminate the operation immediately and start it from the beginning again.



- **For specified application only.**

The use of a pump in an application other than those clearly specified may result in injury or damage to the pump. Use the pump strictly in accordance with the pump specifications and application range.



- **No remodeling.**

Never remodel a pump. Otherwise, a serious accident may result. Iwaki will not be responsible for any accident or damage of any kind which is caused by the user remodeling the pump without first obtaining permission or instructions from Iwaki.



- **Wear protectors.**

If you touch or come in contact with any type of hazardous chemical liquid, including but not limited to chemicals, you may experience a serious injury. Wear protective gear (protective mask, gloves, etc.) during the pump operation.



Caution

- **Qualified operators only.**

The pump operator and pump operation supervisor must not allow any operators who have little or no knowledge of the pump to run or operate the pump. Pump operators must have a sound knowledge of the pump and its operation.



- **Specified power only.**

Do not operate the pump on voltage which is not specified on the nameplate. Failure to do so may result in damage or fire. Only the specified power level is to be applied.



- **Do not wet or dampen.**

If the motor or wiring cable becomes wet or dampened with the operating liquid by mistake, this may result in a fire or cause an electrical shock. Install the motor and wiring cable in positions which are not likely to become wet or dampened with any liquid.



- **Ventilate.**

Poisoning may result during an operation which involves toxic or odorous liquid. Ventilate the operating site sufficiently.



- **Spill-out accident.**

Protective measures should be taken against any accidental spill-out or leakage of the operating liquid as a result of unexpected damage on the pump or the related piping.



Caution

- **Operating site must be free of water and humidity.**

The pump is not designed to be water-proof or dust-proof. The use of the pump in places where water splashes or humidity is high may result in an electrical shock or short circuit.



Prohibited

- **Do not damage power cable.**

Do not scratch, damage, process, or pull the power cable forcibly. An extra load onto the cable, such as heating the cable or placing something heavy on the cable, may damage the cable and finally cause a fire or an electrical shock.



Caution

- **Do not cover the motor.**

Running a covered motor may accumulate heat inside the motor and cause a fire or a mechanical failure. Ventilate the motor sufficiently.



- **Do not apply pressure to pump chamber.**

Do not apply pressure to pump chamber exceeding the pressure generated by pump operation. Otherwise liquid may leak through O ring or pump may be damaged.



Prohibited

- **Power cable cannot be replaced.**

Never use a damaged or affected power cable. Otherwise, a fire or an electrical shock may result. Handle the power cable carefully, as it cannot be replaced by a new cable. (The complete motor must be replaced in that circumstance.)



Caution

Caution

- **Limited operating site and storage.**

Do not install or store the pump in the following places:

- * Places where a flammable gas or material is used or stored.
- * Places where the ambient temperature is extremely high (40°C or higher) or extremely low (0°C or lower).



Prohibited

- **Do not drain the liquid in the site.**

The liquid discharged out of the pump, including a hazardous chemical liquid, must be drained into a special container. Never drain such liquid directly onto the floor in or near the operation site.



Prohibited

- **Disposal of used pump.**

Disposal of used or damaged pumps must be done in accordance with the relevant local laws and regulations. (Consult a licensed industrial waste products disposing company.)



- **Countermeasure for static electricity.**

When low electric conductivity liquid such as ultra-pure water and flour inactive liquid (e.g. Fluorinert™) are handled, the static electricity may be generated in pump, which may cause static discharge and break down of pump. Take countermeasure to avoid and remove static electricity.



2. Unpacking and Inspection

After unpacking the product, check the following points.

- [1] Do the model, flow and head indicated on the nameplate correspond with your order?
- [2] Has the pump or any part of it been damaged as a result of accident or handling during shipment?

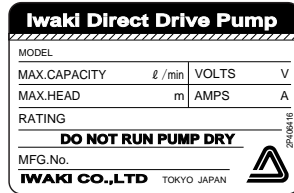

If you find any discrepancy, please contact your dealer.

3. Operating Principle

RD Series pump is canned motor type centrifugal pump driven by DC brushless motor. The magnet incorporated with impeller is directly rotated in the pump chamber by the magnetic force of motor to discharge the liquid from suction port to the discharge port.

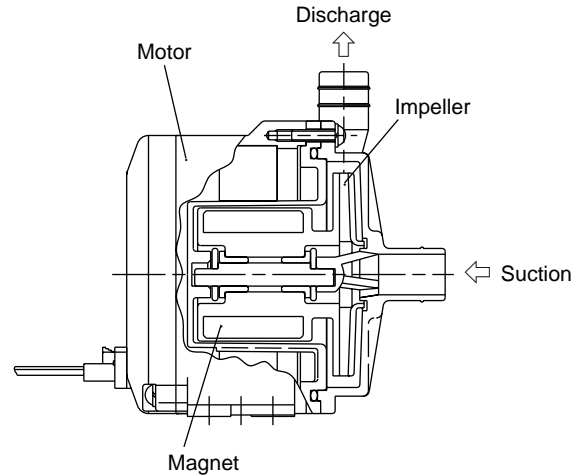

5. Dimension

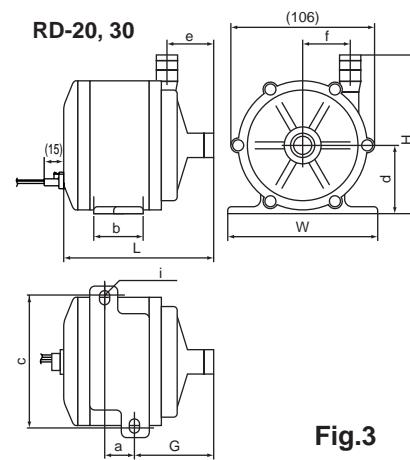
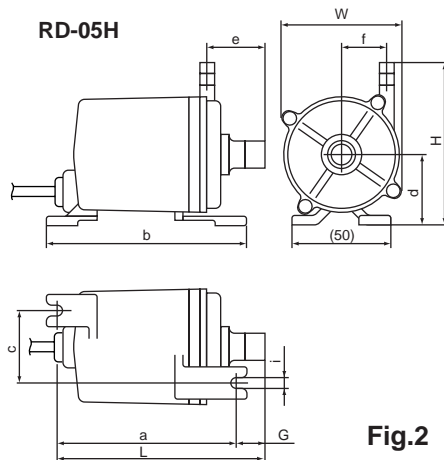
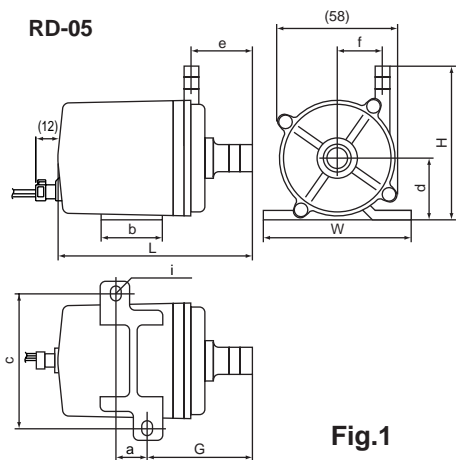

(mm)

Model	W	H	L	a	b	c	d	e	f	G	i	Fig.
RD-05	76	75	94.5	16	30	64	30	29.5	22.4	50.5	2- ϕ 5 \times 7.5	Fig.1
RD-05H	58	78	108	90	100	35	33	29.5	22.4	14.5	2-6	Fig.2
RD-20/30	112	119	110	22	37	97	49	35	36	59.5	2- ϕ 6 \times 8	Fig.3

6. Performance Curve

● RD-05/05H

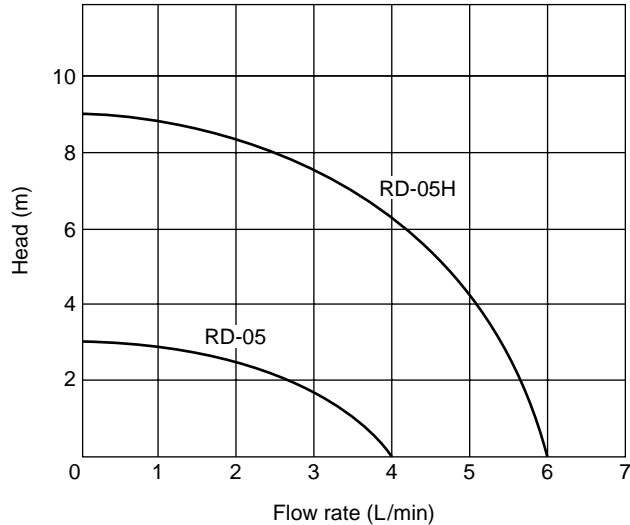

Water cutting sound is generated when RD-05H is used at head of 2m or lower.

● RD-20/30

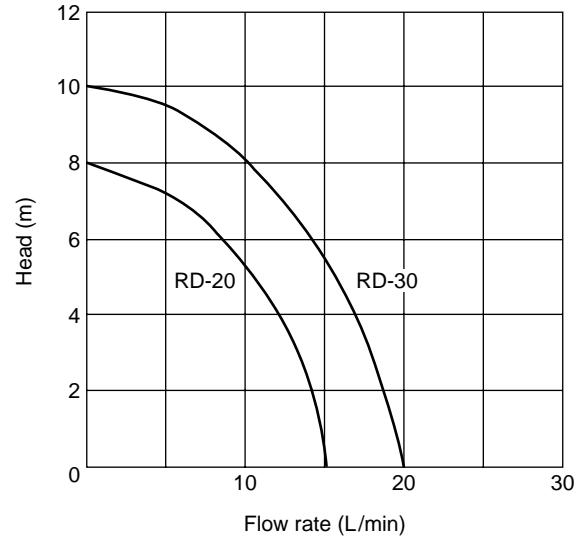

Water cutting sound is generated when RD-20 is used at head of 4m or lower, and RD-30 at head of 5m or lower.

7. Main Parts and Label

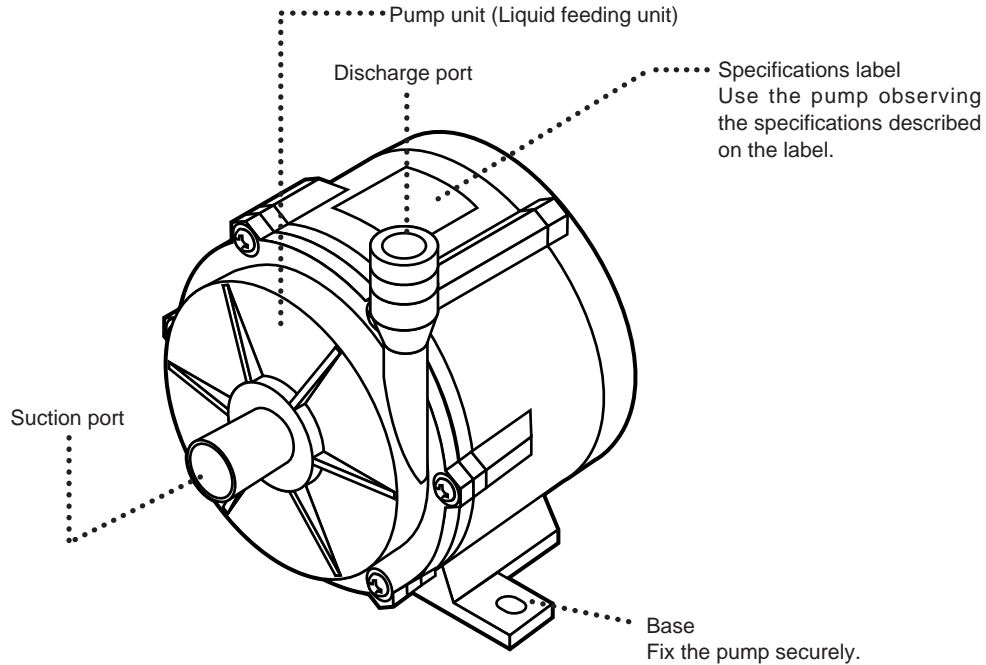

8. Name of Parts

RD-05/05H

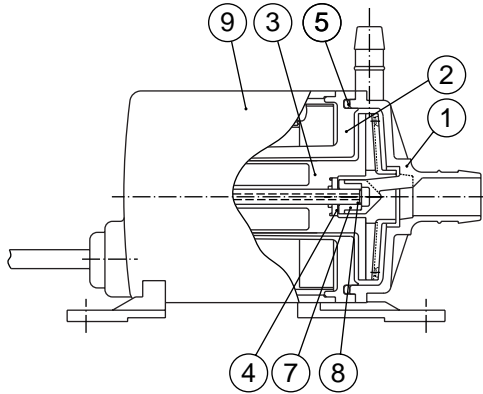

No.	Parts name	Q'ty	Material
1	Front casing	1	PPE
2	Rear casing	1	PPE
3	Impeller	1	GFRPP
4	Thrust	2	Ceramic
5	O ring	1	FKM or EPDM
7	Bearing	2	PPS or Carbon
8	Spindle	1	Ceramic
9	Motor	1	

RD-20/30

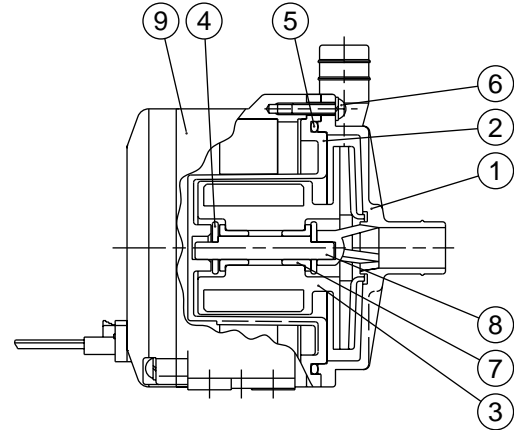

No.	Parts name	Q'ty	Material
1	Front casing	1	PPE
2	Rear casing	1	PPE
3	Impeller	1	GFRPP
4	Thrust	2	Ceramic
5	O ring	1	FKM or EPDM
6	Pan head screw (with SW, PW)	6	Stainless steel
7	Bearing	2	PPS or Carbon
8	Spindle	1	Ceramic
9	Motor	1	

9. Handling

Warning

- Switch off the power when the pump or its electrical parts get wet.
- Keep the pump away from fire
For the safety, do not place dangerous or flammable substances near the pump.

Caution

- Do not put near the pump the goods such as watch and floppy disk which do not like magnet because the pump has strong magnet inside.
- Do not run pump dry (without liquid inside pump).
Otherwise, the pump is damaged by frictional heat.

(1) Handle the pump carefully

Strong impacts caused by dropping the pump on the floor or striking it may result in damage or faulty performance.



(2) Priming water

Be sure to fill the pump unit with liquid as priming water before pump operation.

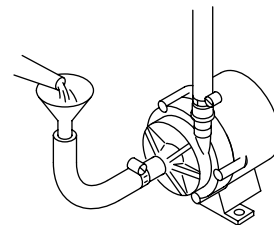

- #### (3)
- As there is a powerful magnet inside the pump unit, do not use any liquid that contains metallic substances such as iron, nickel, etc.

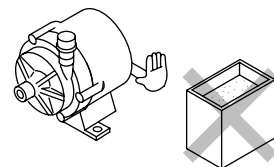

(4) Do not operate the pump in the following places

- The pump unit is not designed to be dust and water-proof.
 - Places exposed to rain and/or wind.
 - Places where the temperature falls below 0°C.
 - Places where corrosive gas (such as chlorine gas) is generated.
- Places exposed to splashing or dropping of water.
- Places where the ambient temperature is 40°C or above.
- Places where explosive.

- (5) Do not operate the pump with the following liquids
- For the compatibility to chemical liquid or any special liquid, contact IWAKI sales representative.
 - Liquids that significantly swell used plastics.
- | |
|---|
| <ul style="list-style-type: none">· Paraffinic hydrocarbons such as gasoline and kerosene· Halogenated hydrocarbons such as trichloroethylene and carbon tetrachloride· Ether and low-grade ester |
|---|
- Slurry
(Never use slurry, which wears out the pump bearing.)

(6) If pump is damaged

Do not operate a damaged pump, otherwise there may happen the electricity leakage or electric shocks.

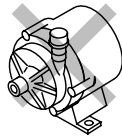

(7) Power cable

Broken power cable may cause fire or electrical shock. Do not bend, pull or twist it by force. Consult IWAKI if power cable is damaged.

- (8) Do not clean the pump with solvent such as benzene, alcohol etc. Otherwise, the paint may come off.

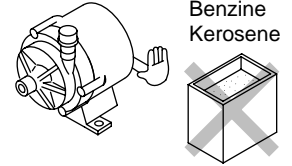

- (9) Do not wet the pump because it is not dust and water proof.

10. Installation, Piping and Wiring

10-1. Installation

(1) Installation site

An installation site must be an ambient temperature of 0~40°C and a relative humidity of lower than 85%. Install the pump at the place where the maintenance and inspection work can be done easily.

(2) Pump installation method

This pump is not the self-priming pump. The pump should be installed in a position lower than the liquid level of the suction tank.

Liquid level must be higher by 30 cm than the pump suction port level. If this distance is too short, the air may be sucked in the pump, which will cause abnormal wear of pump bearing.

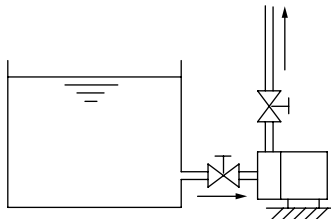

(3) Anchoring of base

The base of the pump must be anchored firmly.

The pump must not be mounted in a vertical position.

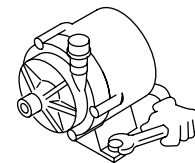

(4) Hose preparation

The ends of the hoses should be cut flat before connecting them.

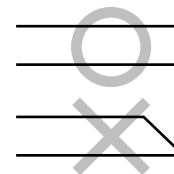

10-2. Piping

Piping instructions

- (1) To minimize the friction resistance, the shortest piping possible with the minimum number of bends should be utilized. Especially for suction piping, employ as larger and shorter hose as possible.

- (2) Use a corrosion-resistant vinyl hose that can endure the pressure made by the pump operation.

If the connection on the suction side is inadequate, air may be mixed in.

- (3) Hose size

Select a hose in accordance with the diameter of the pump port. A reliable connection is not guaranteed if different size of hose is used.

As the hose on the suction side, in particular, tends to be crushed under the sucking force, the use of a braided hose is recommended. **(In the case of hot liquid feeding, special attention must be paid in the selection of a hose.)**

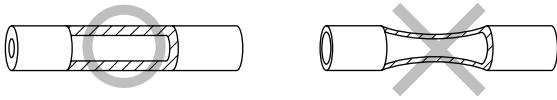

- (4) Valve installation

Install valves close to the suction and discharge port.

- Suction side valve:
For easy removal or maintenance of the pump.
- Discharge side valve:
For adjustment of the discharge rate or head.

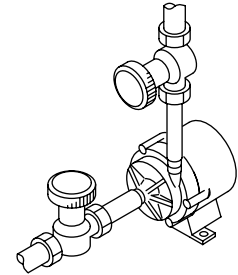

- (5) Hose connection

Press the hose end firmly against the discharge or suction port until it reaches the bottom of the port.

*Use a fastener (such as a hose band) to make the connection firm and free of liquid leakage.

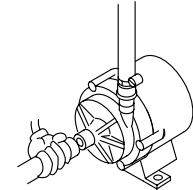

Caution

Do not tighten the connection ports (suction and discharge) excessively as they are made of plastic resin and are easily damaged.

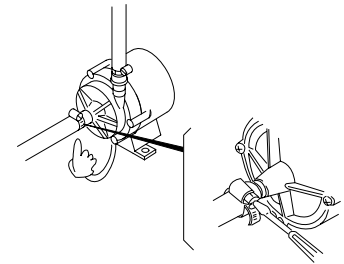

- (6) Pay attention the load is not applied to inlet and outlet port.

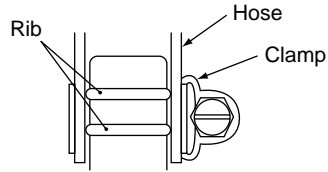

10-3. Wiring

- (1) Before you start wiring works, check to see if the main power is switched off.
- (2) Follow your local law for wiring works.
- (3) Use specified voltage written on pump nameplate.
- (4) Pump has no ON/OFF switch. Pumps starts when power cable is connected. Do not do frequent ON/OFF operation.
- (5) In case external fuse is installed
When fuse blew out, replace it and start pump after you settled the reason of blew out fuse.
If the fuse blows out frequently, it may be caused by the starting current.
- (6) Wires have polarity. Red is plus and black is minus. Wrong polarity will damage the motor.
Motor does not rotate in reverse if the wires are connected in reverse.

Rated current, starting current

Model	Rated current	Starting current
RD-05V24	0.4A	1.5A
RD-05HV24	1.6A	4A
RD-20V24	2.5A	8A
RD-30V24	3.2A	10A

- (7) If pump is switched ON and OFF, install the switch at the secondary side of DC power source (between power source and pump). If power is ON and OFF at the primary side of DC power source, it is possible pump can not start.

Good

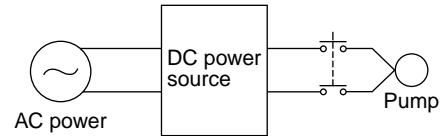

No good

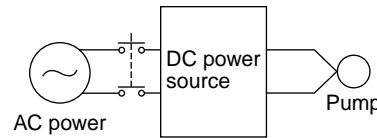

Wiring example

11. Operation

■ Operation instructions

Caution

- *Before operating the pump, confirm that the pump is securely fixed and the hoses connected with the discharge port and suction port are firmly fixed in position.*
- *Dry operation (operation without liquid in the pump) damages the pump. Be sure to fill the pump with priming liquid in advance.*
- *Do not keep on operating the pump with entirely or almost closed discharge or/and suction side valve(s).*
- *Do not open or close the suction or discharge side valve suddenly, otherwise the protective circuit operates, disabling the rotation of the impeller. (Under such circumstances, turn off the power supply.*
- *Frequent ON and OFF may cause the failure or damage of pump.*
- *If foreign matters get into pump, switch off power and remove them. Otherwise pump may be failed or damaged.*

■ Operation

After the installation, piping and wiring processes are completed, operate the pump in accordance with the following steps.

No.	Operation step	Description (Points to be checked)
1	Check piping, wiring and voltage.	Check in accordance with the 'Hose connection' and 'Wiring' sections. Check the power supply voltage by referring to the information on the nameplate.
2	Open and close valves.	Fully open suction side valve. Fully close discharge side valve.
3	Check that pump chamber is filled with liquid.	Fill pump chamber with priming water (feeding liquid). Carry out sufficient priming in case of suction lift method.
4	Supply power to pump	After steps 1 to 3 above, connect power supply to start pump. When pump is switched ON and OFF, take the interval of five or more seconds to switch ON again after switched OFF.

No.	Operation step	Description (Points to be checked)
5	Adjust discharge capacity & head to desired ones.	Adjust discharge side valve gradually till desired discharge capacity and head are obtained. <u>Do not open or close valves suddenly.</u> Note: Do not keep discharge side valve closed for more than 1 minute for flow rate of 0.1 L/min. or less. Note: Check that pump feeds liquid normally. If not, turn off power immediately and eliminate cause referring to 'Causes of Trouble and Troubleshooting' section.
6	Checkpoints during operation	Be careful to prevent foreign matters from entering pump. Foreign matters in pump may cause impeller to be locked, hindering liquid circulation. Motor itself continues to rotate even if impeller is locked. In such a case, turn off power supply at once. When earth leakage breaker is activated, turn off power supply at once and eliminate cause by referring to 'Causes of Trouble and Troubleshooting' section.

■ Pump Stopping Procedure

No.	Stopping step	Description
1	Close discharge side valve.	Close discharge side valve gradually. Do not use electromagnetic valve for quick closing.
2	Turn off power supply. (Check stopping condition.)	Check that motor stops smoothly after power is disconnected. If not, pump should be inspected. (For details, contact Iwaki or your dealer.)

■ How to store pump when it is out of use for a long time

Remove the liquid from the pump when it is stored for a long time. In addition, run it with water circulating for about 5 minutes every 3 months to prevent rust on the motor bearing.

Draining Method

Warning

- *Before starting the draining procedure, turn off the power supply.*
- *Be sure to wear proper safety gear (gloves, protective shoes, etc.) during draining work. When chemical liquid is used, wear rubber gloves, goggles).*

Caution

- *Pay special attention to the remaining liquid which may run out of the discharge port or the suction port when removing the hose. Pay attention not to allow the motor or electric parts to come into contact with the liquid.*
- *Never discharge hazardous or chemical liquid over the ground or floor in the plant. Instead, use a draining pan (or container). Observe each applicable local law or regulation for the handling or disposal of hazardous liquids.*
- *Motor is not dust and water proof construction. Do not wet pump.*

Draining procedure:

- (1) Turn off the power supply.
(Make sure no other operator will turn on the power supply accidentally.)
- (2) Fully close the discharge and suction sides valves.
- (3) Remove the hoses connected with the discharge and suction ports.

Position the draining pan below the pump unit in advance. Loosen the hose band and rotate the hose clockwise and counterclockwise slowly to completely pull the hose off of each port. (Liquid will run out when the hose is disconnected.)

- (4) Remove the screws on the pump base to detach the pump unit.
- (5) Direct the discharge port downward to drain the liquid into the draining pan.

Never discharge hazardous liquid, over the ground or the floor inside the plant. Use a draining pan (or container).

12. Troubleshooting and Maintenance

Cause \ Trouble	Excessive heat	Pump does not start.	Pumping is not done or insufficient.	Electric current is too high.	Excessive noise or vibration.	Liquid leaks.	Troubleshooting
Power is not supplied or wiring is faulty.		<input type="radio"/>		<input type="radio"/>			Check and correct wiring.
Motor is out of order (disconnected coil or capacitor failure).	<input type="radio"/>	<input type="radio"/>		<input type="radio"/>	<input type="radio"/>		Contact your dealer.
Air in pump.			<input type="radio"/>		<input type="radio"/>		Eliminate air completely.
Air is sucked in via suction port.			<input type="radio"/>				Fasten hose tightly.
Pump runs dry.			<input type="radio"/>	<input type="radio"/>	<input type="radio"/>		Check piping.
Specific gravity/viscosity of liquid is too high.	<input type="radio"/>	<input type="radio"/>	<input type="radio"/>	<input type="radio"/>			Use suitable type of pump.
Impeller magnet touches rear casing.			<input type="radio"/>	<input type="radio"/>	<input type="radio"/>		Contact your dealer.
Impeller is damaged.		<input type="radio"/>	<input type="radio"/>	<input type="radio"/>	<input type="radio"/>		Contact your dealer.
Foreign matter adheres to impeller.			<input type="radio"/>	<input type="radio"/>	<input type="radio"/>		Contact your dealer.
O ring is damaged.						<input type="radio"/>	Contact your dealer.
Loosened front casing fixing bolts.			<input type="radio"/>			<input type="radio"/>	Tighten bolts.
Too high liquid & amb. temp	<input type="radio"/>						Contact your dealer.
Lack of power volume.		<input type="radio"/>					Check power volume.

Maintenance

(1) Tighten bolts

While the pump is running for a long time, it may happen the bolts are loosened. In this case tighten the bolts. Also tighten the bolts after the pump are stocked for a long period.

(2) Daily inspection

Check to see the operating condition of pump such as vibration, sound, electric current and flow rate and as soon as you find any abnormality, switch off the power and settle the abnormality referring to the item “Troubleshooting”.

(3) Spare parts (Consumable parts)

When the pump is continuously used for a long period, we recommend you to stock consumable parts such as impeller and O ring).



()Country codes
 IWAKI CO.,LTD. 6-6 Kanda-Sudacho 2-chome Chiyoda-ku Tokyo 101-8558 Japan
 TEL:(81)3 3254 2935 FAX:3 3252 8892(<http://www.iwaki-pumps.co.jp/>)

U.S.A. : IWAKI WALCHEM Corporation	TEL : (1)508 429 1440	FAX : 508 429 1386	Germany : IWAKI EUROPE GmbH	TEL : (49)2154 9254 0	FAX : 2154 1028
Australia : IWAKI Pumps Australia Pty. Ltd.	TEL : (61)2 9899 2411	FAX : 2 9899 2421	Italy : IWAKI Italia S.R.L.	TEL : (39)02 990 3931	FAX : 02 990 42888
Singapore : IWAKI Singapore Pte. Ltd.	TEL : (65)763 2744	FAX : 763 2372	Denmark : IWAKI Pumper A/S	TEL : (45)48 24 2345	FAX : 48 24 2346
Indonesia : IWAKI Singapore (Indonesia Branch)	TEL : (62)21 392 8288	FAX : 21 392 8088	Sweden : IWAKI Sverige AB	TEL : (46)8 511 72900	FAX : 8 511 72922
Malaysia : IWAKIm Sdn. Bhd.	TEL : (60)3 703 8807	FAX : 3 703 4800	Finland : IWAKI Suomi Oy	TEL : (358)9 2742714	FAX : 9 2742715
Taiwan : IWAKI Pumps Taiwan Co., Ltd.	TEL : (886)2 8227 6900	FAX : 2 8227 6818	Norway : IWAKI Norge AS	TEL : (47)66 81 16 60	FAX : 66 81 16 61
Thailand : IWAKI (Thailand) Co.,Ltd.	TEL : (66)2 320 1303	FAX : 2 322 2477	France : IWAKI France S.A.	TEL : (33)1 69 63 33 70	FAX : 1 64 49 92 73
Hong Kong : IWAKI Pumps Co., Ltd.	TEL : (852)2 607 1168	FAX : 2 607 1000	U.K. : IWAKI PUMPS (UK) LTD.	TEL : (44)1743 231363	FAX : 1743 366507
China : IWAKI Pumps Co., Ltd. (Guangzhou office)	TEL : (86)20 8130 0605	FAX : 20 8130 0601	Switzerland : IWAKI (Schweiz) AG	TEL : (41)32 3235024	FAX : 32 3226084
China : IWAKI Pumps Co., Ltd. (Beijing office)	TEL : (86)10 6442 7713	FAX : 10 6442 7712	Austria : IWAKI (Austria) GmbH	TEL : (43)2236 33469	FAX : 2236 33469
China : IWAKI Pumps (Shanghai) Co., Ltd.	TEL : (86)21 6272 7502	FAX : 21 6272 6929	Holland : IWAKI Holland B.V.	TEL : (31)297 241121	FAX : 297 273902
Philippines : IWAKI Chemical Pumps Philippines, Inc.	TEL : (63)2 888 0245	FAX : 2 843 3096	Spain : IWAKI Iberica Pumps, S.A.	TEL : (34)943 630030	FAX : 943 628799
Korea : IWAKI Korea Co.,Ltd.	TEL : (82)2 3474 0523	FAX : 2 3474 0221	Belgium : IWAKI Belgium n.v.	TEL : (32)1430 7007	FAX : 1430 7008