

Kleindrehschieberpumpe
DS 60 - 940
selbstansaugend

small roller vane pump
DS 60 - 940
self priming

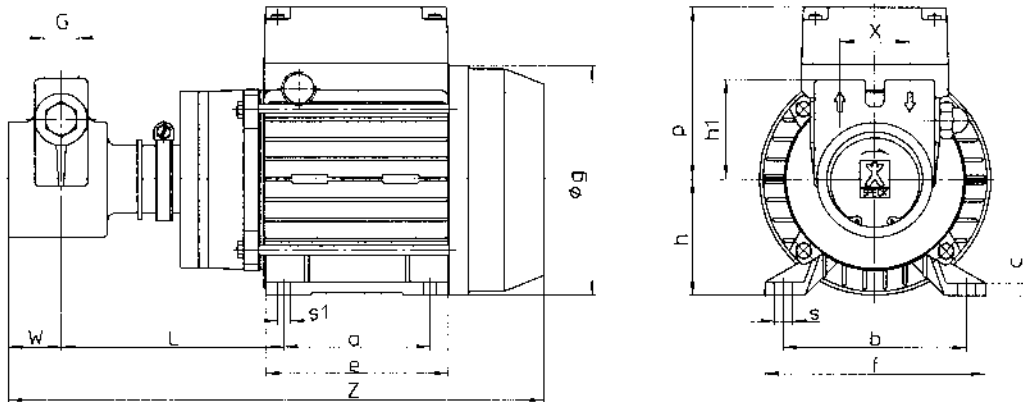

Type / type	G	X	W	L	Z	a	b	c	e	f	Ø g	h	h1	p	s	s1
DS 60 - 450	G 3/8	38	25	101	268	80	100	7	100	120	126	63	50	95	10	7
DS 540 - 940	G 1/2	48	32	128	321	90	112	12	125	153	142	71	63	105	12	9

Wellendichtung:	Gleitringdichtung			shaft sealing:			mechanical seal											
Werkstoffe:	Gehäuse	Steuerscheibe	Mittelkörper	Läufer	CuZn	Kohle	Kohle	1.4301	(1.4581) (Kohle)	materials:	casing	inter casing	stage casing	rotor	brass	Carbon	Carbon	(stainless steel) (Carbon) (Carbon) (AISI 304)
Anschlüsse:	DS 60 - 450	DS 540 - 940	G 3/8	G 1/2	connections:			DS 60 - 450	DS 540 - 940	G 3/8	G 1/2							
Motor:	BG 63: 0,18 oder 0,3 kW ; 1450/1750 1/min BG 71: 0,37 kW ; 1450/1750 1/min BG 80: 0,55 oder 0,75 kW ; 1450/1750 1/min Einphasen-/Drehstrommotor ; Gleichstrommotor auf Anfrage				motor:				motor frame size 63: 0.24 or 0.40 HP; 1450/1750 rpm motor frame size 71: 0.5 HP; 1450/1750 rpm motor frame size 80: 0.74 or 1.00 HP; 1450/1750 rpm single-phase / three-phase motor; DC-motor upon request									
Gewicht:	auf Anfrage				weight:				upon request									

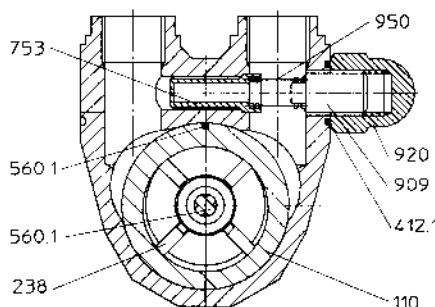
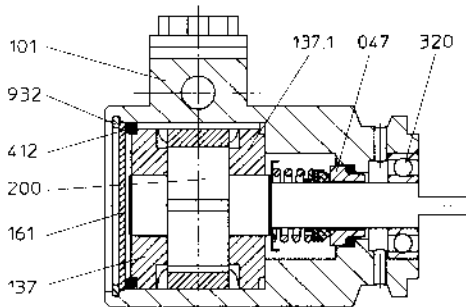

- 047 Gleitringdichtung mechanical seal
- 101 Gehäuse casing
- 110 Mittelkörper stage casing
- 137 Steuerscheibe inter casing
- 137.1 Steuerscheibe inter casing
- 161 Gehäusedeckel casing cover
- 200 Läufer rotor
- 238 Laufradschieber vanes
- 320 Kugellager ball bearing
- 412 Runddichtring O-ring
- 412.1 Runddichtring O-ring
- 560 Stift pin
- 560.1 Stift pin
- 753 Ventilkegel valve cone
- 909 Einstellschraube adjusting screw
- 920 Hutmutter cap nut
- 932 Sicherungsring locking ring
- 950 Druckfeder spring

