



**TX SERVICE PAK INSTRUCTIONS**

<b>Suggested Service Pak Tools</b>			
60130-1	Bearing Extractor Tool	60152-1	Phillips Screwdriver
60020-1	Bearing Installation Tool	Optional	Rubber Gloves
60151-1	Medium Blade Screwdriver	Optional	Masking Tape
60150-1	T Series Tool Kit (Includes all tools shown above)		

Service Pak includes: 2 Gears, 4 O-Rings, 5 Bearings, Silicone Lubrication and Instruction Sheet.

**WARRANTY WILL NOT EXTEND TO GOODS ALTERED OR REPAIRED BY ANYONE OTHER THAN THE MANUFACTURER OR AUTHORIZED REPRESENTATIVE**

**NOTE:** Service Paks are designed to be installed by someone familiar with precision mechanical assemblies and tools. Observe reasonable safety precautions, including the use of safety eyewear when performing the steps listed below.

**IMPORTANT:** To prevent damage to the Driving Gear Assembly (17) REMOVE Cap (6) BEFORE installing or removing the Magnet Screw (15). NEVER install or remove the Magnet Screw with Cap (6) in place.

**DISASSEMBLY INSTRUCTIONS**

1. Provide a clean surface for work area.
2. Remove two Pump Mounting Screws (1) and one Pump Mounting Screw (2) and separate Pumphead from Drive Housing.
3. With a permanent marker mark the relative positions of the Mounting Plate (3), the Body (4), the Cavity Plate (5) and the Cap (6) orientation for ease in reassembly.
4. **Note:** If the Gears are not being replaced and will be reused, after removing the Cap (6) in the next step mark the Gear orientation with a marker. This will allow the Gears to be reassembled in the same orientation.
5. Remove two Pump Screws (7) and three Pump Screws (8) in the Cap (6) holding the other parts in place and remove the Cap, Driven Gear Assembly (9), Cavity Plate (5) and two Dowel Pins (10).
6. Remove Clamp Plate Screws (11); remove the Clamp Plate (13) and Magnet Cup (12).
7. Hold the Driven Magnet (14), and turn Magnet Screw (15) counter-clockwise to remove. **Note:** Pumps produced prior to 1995 utilized left-hand threads for the Magnet Screw (15), remove by turning clockwise. Pumps produced after 1995 utilized right-hand threads.
8. Remove four O-Rings (19, 20, 21) from the Cap (6) and Body (4). O-Rings may be removed with a blast of compressed air or with a sharp pin.
9. Complete disassembly of Body (4), Mounting Plate (3) and Driving Gear Assembly (17).
10. **Important:** Do not nick or scar the sides of the bearing bores in the steps below.
11. **Note:** Mark the location of the Bearing (18) lubrication grooves with a permanent marker on the Cap (6) and Body (4) before removing the Bearings. The Bearing lubrication grooves should be as far away from the inlet (suction) port as possible.
12. Clamp the Bearing Extractor Tool in a vise and screw the Bearing (18) on the tool and gently tap with a soft mallet while supporting and pulling the Cap (6) or Body (4) to free the Bearing. Repeat process until all five Bearings are free. If necessary remove Bearings by carefully breaking out the bearing material with a small chisel and mallet. See figure 2.
13. Inspect all parts for damage and wear. If wear on Cap (6), Cavity Plate (5) and Body (4) is excessive rebuilding the pump may not be recommended (consult factory).

**ASSEMBLY INSTRUCTIONS**

- A. Clean all parts. Any foreign material clinging to the Driven Magnet (14) can be removed with masking tape.
- B. Align the Bearing (18) lubrication grooves with the marks made during Bearing removal in step 12.
- C. Using the Installation Tool press five new Bearings into the Cap (6) and Body (4). Bearings should be .002/.005 below the face of the Cap (6) and Body (4). See figure 3.

<b>Title: D Service Pak Instructions</b>		<b>Page 1 of 3</b>	
<b>Document: 70012-1</b>	<b>Date: 11/21/02</b>	<b>Revision: I ECO 50-4070</b>	<b>File name: D Service Pak Instructions</b>



- D. Omit silicone lubricant if it is incompatible with your pumped fluid.
- E. Using alignment marks made in step 3 during disassembly carefully assemble the Mounting Plate (3) and Body (4) together with a slight twisting action until fully seated taking care not to dislodge or pinch the O-Ring.
- F. Install Driving Gear Assembly (17), Magnet Pin (16), Driven Magnet (14), and Magnet Screw (15). Hold Driven Magnet to prevent rotation and tighten Magnet Screw clockwise to 960 in/oz torque (a rubber glove can be used to facilitate holding the Driven Magnet).
- G. **Note:** When performing the following assembly operations DO NOT apply forces to the Driven Magnet (14). Pushing or pulling the Driven Magnet may damage the Driving Gear Assembly (17).
- H. Confirm the presence of the plastic plug located in the lower Dowel Pin (10) hole of the Body (4). This is to prevent the Dowel Pin from slipping out. Install two Dowel Pins into Body (4) and slip the Cavity Plate (5) onto the Dowel Pins against the Body (4) face. The Cavity Plate (5) will fit properly in only one orientation. All the Screw holes in the Body (4) and Cavity Plate must align.
- I. Install Driven Gear Assembly (9).
- J. Align Cap (6) with the Driving (17) and Driven (9) Gear Assembly shafts and Dowel Pins (10).
- K. Install two Pump Screws (7) and three Pump Screws (8) in Cap (6) and torque alternately to 640 in/oz.
- L. Rotate the Driven Magnet (14) by hand to check for any binding during rotation. The Driven Magnet should turn freely. If there is binding determine and remove cause.
- M. Orient Clamp Plate (13) so that protruding Pump Screws (7) are aligned with the clearance holes provided in the Clamp Plate. Install the Magnet Cup (12) and Clamp Plate with Clamp Plate Screws (11) and torque alternately to 320 in/oz.
- N. Assemble Pumphead to Motor and Drive Housing with three Pump Mounting Screws (1 & 2). Pump/Motor assembly is now complete.
- O. **Note:** New parts may exhibit slight interference with mating surfaces. An initial "run-in" period may be required to allow the gears to seat. Rebuilt pumps may initially decouple below normal differential pressure or produce less than normal flow-rate until mating parts have fully seated during initial period of operation.

Reference numbers on page 3:

- 1. Pump Mounting Screw (to mount pumphead to housing, 2 ea.)
- 2. Pump Mounting Screw (to mount pumphead to housing, 1 ea.)
- 3. Mounting Plate (316 SST)
- 4. Body
- 5. Cavity Plate
- 6. Cap
- 7. Pump Screw (through cap, cavity plate & body into mounting plate, 2 ea.)
- 8. Pump Screw (through cap & cavity plate into body, 3 ea.)
- 9. Driven Gear Assembly
- 10. Dowel Pin
- 11. Clamp Plate Screws
- 12. Magnet Cup
- 13. Clamp Plate
- 14. Driven Magnet
- 15. Magnet Screw
- 16. Magnet Pin
- 17. Driving Gear Assembly
- 18. Bearings
- 19. O-Ring
- 20. O-Ring
- 21. O-Ring

<b>Title: T Service Pak Instructions</b>			<b>Page 2 of 3</b>
<b>Document: 70012-1</b>	<b>Date: 11/21/02</b>	<b>Revision: I ECO 50-4070</b>	<b>File name: T Service Pak Instructions</b>

NOTES: (UNLESS OTHERWISE SPECIFIED)

PRODUCTION REVISIONS		DATE	CAD	ENG
1	50-4070			

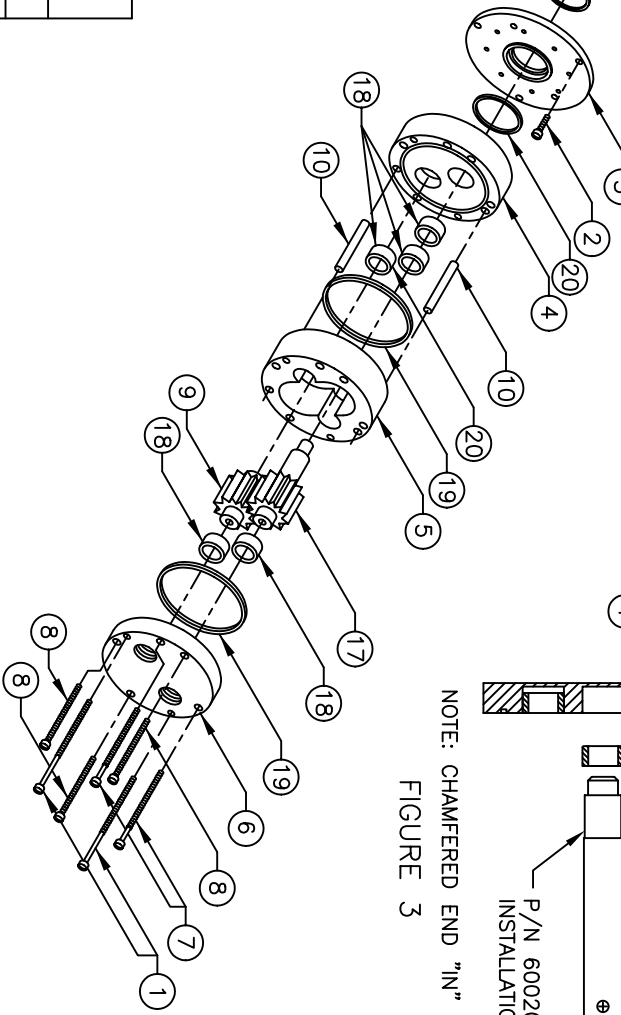
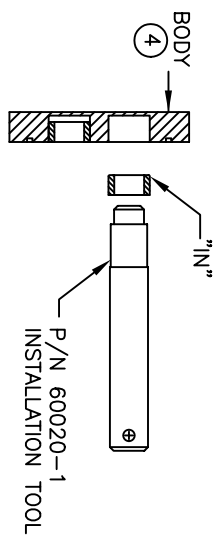
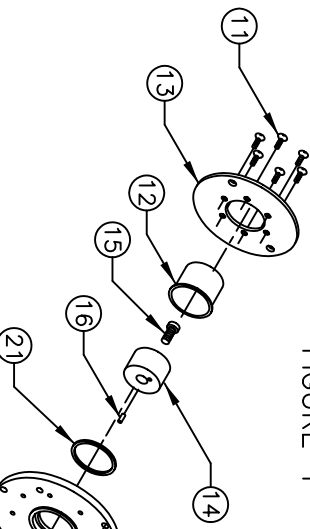
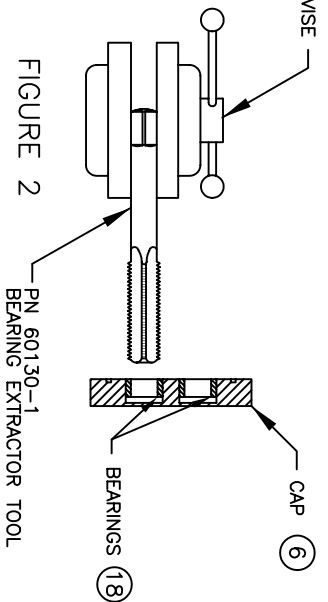
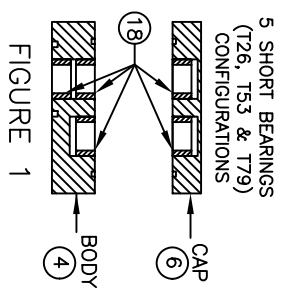

SCREW CHART

Pump Model	Size	Qty	Item
7.9	5.3	2.6	
2 1/2	2 1/4	2	10-32
2	1 1/2	2	10-32
5/8	5/8	1	8-32
2 3/4	2 3/4	2	8-32
1/4	1/4	1/4	6-32
1	1	1	10-32

NOTICE: This drawing and the principles and elements of design embodied therein are the exclusive property of TUTHILL PUMP GROUP, CONCORD OPERATIONS-A DIVISION OF TUTHILL CORPORATION and are not to be communicated, disclosed, reproduced, or used except as previously authorized in writing by said company and must not be submitted to outside parties for examination without the consent of said company.

UNLESS OTHERWISE SPECIFIED DIMENSIONS ARE IN INCHES. TOLERANCES ARE: .XX = ±.01 .XXX = ±.002 DO NOT SCALE DRAWING		TUTHILL CORPORATION Concord Operations Concord California USA	
FRACTIONS = ±1/32 ANGLES = ±0°-30' SURFACE FINISH = v SURFACE FINISH = v DO NOT SCALE DRAWING		TX-SERIES PUMPHHEAD	
CHECKED	DATE	DRAWING NUMBER	REV
ENGINEERED	DATE	70012	1
DRAWN T.HOEBORN		SCALE NONE	
DATE 11-12-02		SHEET 3 OF 3	